



ORC Sportboat European Championship
Kalamaki, Greece, 25 September – 1 October 2023

Sailing Instructions

The notation '[NP]' in a rule of these Sailing Instructions (SIs) means that a boat may not protest another boat for breaking that rule. This changes RRS 60.1(a).

1 Changes to Sailing Instructions

Any change to the Sailing Instructions will be posted one hour before on the day it will take effect, except that any change to the schedule of races will be posted by 21:00 on the day before it will take effect.

2 Communications with competitors

- 2.1 Notices to competitors will be posted on the official notice board, which will be electronic, at the following URL: <https://www.racingrulesofsailing.org/documents/4825/event>.
- 2.2 On the water, the race committee intends to monitor and communicate with competitors on VHF radio channel 74.
- 2.3 The following communications may be made by the race committee on VHF: time checks and starting times, starting order and designation of race areas, confirmation of any visual signal displayed, courses including bearing and distance to the first mark, change of course, shortening, postponement, abandonment and other information explaining the intentions of the race committee.

Delay in the broadcast of these calls, or the order in which they are made, or any omission or failure in the transmission or reception of these, will not be grounds for a request for redress by a boat. This changes RRS 62.1(a).

3 Signals made ashore

- 3.1 Signals made ashore will be displayed at the flagpole located at the hosting club.
- 3.2 When flag AP is displayed ashore '1 minute' is replaced with 'not less than 30 minutes' in race signal AP. This changes race signals AP.

4 Schedule of races

- 4.1 Times of the first warning signals are defined as follows:

Thursday,	28 September	- 11:00 first warning signal Coastal race
Friday,	29 September	- TBA Windward/leeward races
Saturday,	30 September	- TBA Windward/leeward races
Sunday,	1 October	- TBA Windward/leeward races

- 4.2 There will be no more than 3 races per day.
- 4.3 Flag D displayed on the Finishing line means “There will be one more race after the one in progress.” The warning signal for the subsequent race, will be given as soon as possible. To alert

boats that a race or sequence of races will begin soon, the orange starting line flag will be displayed with one sound at least five minutes before a warning signal is made.

- 4.4 On the last day of the regatta no warning signal will be given after 16:00 unless it follows a signal of general recall or postponement (Flag AP) of a race whose first warning signal had been made before 16:00.

5 Class flag

The Class flag will be Numeric Pennant 1.

6 Courses

- 6.1 **Inshore races** - The diagram in SI Appendix 2 shows the course, including the approximate angles between legs, the order in which marks are to be passed, and the side on which each mark is to be left.
- 6.2 **Coastal race** - The course with description of the marks, positions of the starting line, finishing line and the order in which marks are to be passed, the side on which each mark is to be left will be announced no later than Wednesday, September 27 at 18:00 as appendix 3.
- 6.3 No later than the warning signal, the race committee signal vessel may display the approximate compass bearing of the first leg.

7 Marks

7.1 *Windward/leeward races*

- 7.1.1 Marks M1, M1A, M2S, M2P will be Yellow Pyramid Buoys New mark as provided in instruction 10 will be Orange Cylindrical Buoy.
- 7.1.2 Mark M2 will be a gate consisting of two marks (mark M2P and mark M2S). If the gate is not present, mark M2 shall be rounded to port.
- 7.1.3 Starting Marks: The race committee signal boat at the starboard end and a buoy or vessel with a staff displaying an orange flag at the port end.
- 7.1.4 Finishing Marks: The race committee signal boat at the port end and a buoy or vessel with a staff displaying an orange flag at the starboard end.
- 7.1.5 A race committee boat signaling a change of a leg of the course is a mark as provided in instruction 10.
- 7.2 **Coastal race** - The race committee may set a windward mark which will be Orange Cylindrical Buoy to obtain a first leg to windward. If this mark is set, it will be approximately one nautical mile from the starting area. No later than the warning signal the race committee will display the approximate compass bearing from the race committee signal vessel to the windward mark together with either:
- (a) A red flag which indicates the mark shall be left to port, or
 - (b) A green flag which indicates the mark shall be left to starboard.

8 Obstructions

The obstructions, if any, will be announced with the coastal course announcement on Wednesday, September 27.

9 The Start

- 9.1 The starting line will be between staffs displaying orange flags on the starting marks.
- 9.2 If any part of a boat's hull is on the course side of the starting line at her starting signal and she is identified, the race committee will attempt to broadcast on VHF her sail number, bow number or the name of the boat. Delay in the radio broadcast of these calls, or the order in which they are

made, or any omission or failure in the transmission or reception of these, will not be grounds for a request for redress by a boat. This changes RRS 62.1(a).

- 9.3 A boat that does not start within 5 minutes in the windward/leeward races and 20 minutes in the coastal race after her starting signal will be scored Did Not Start without a hearing. This changes RRS 35, A5.1 and A5.2.

10 Change of the next leg of the course

To change the next leg of the course, the race committee will lay a new mark and remove the original mark as soon as practicable. If mark M1 is replaced by a new mark, mark M1A will not be replaced and will no longer be a mark of the course for boats after rounding the new mark. When in a subsequent change a new mark is replaced, it will be replaced by an original mark except that mark M1A will not be replaced.

11 The Finish

- 11.1 *Windward/leeward races* - The finishing line will be between a staff displaying blue flag on the race committee signal boat and a staff displaying an orange flag on the finish buoy mark.

12 Time Limit

- 12.1 *Windward/leeward races*: The Race Time Limit (see RRS 35) will be 2 hours after the starting signal. The Finishing Window is the time for boats to finish after the first boat sails the course and finishes and will be 40 minutes.
- 12.2 *Coastal race*: The time limit for each class is 8 hours after the starting time of the respective class.
- 12.3 Boats failing to finish within the Finishing Window (for windward/leeward races) or their time limit (for coastal race), and not subsequently retiring, penalized, or given redress, will be scored Time Limit Expired (TLE) without a hearing. A boat scored TLE will receive the points of the last boat that finished within its time limit plus one. This changes RRS 35, A5.1, A5.2 and A10.

13 Hearing requests

- 13.1 The protest time limit is 60 minutes after the last boat in that class finishes the last race of the day or the race committee signals no more racing today, whichever is later. The time will be posted on the official notice board.
- 13.2 Hearing request forms are available from the official notice board and can be lodged from the URL: <https://www.racingrulesofsailing.org/documents/4825/event>.
- 13.2 Notices to inform competitors of hearings in which they are parties or named as witnesses will be posted
- a) *Windward/leeward races* - no later than 30 minutes after the protest time limit
 - b) *Coastal race* - within 30 minutes of the finish of all the boats involved in the protest.
- Hearings will be held in the protest room, located at the hosting club.

14 Scoring

The decision on the scoring parameters used will be at the sole discretion of the race committee and together with length of course, directions of leg and the wind direction and speed will not be grounds for request for redress by a boat. This changes RRS 62.1(a).

15 Safety regulations

- 15.1 [DP], [NP] A boat that retires from a race shall notify the race committee at the first reasonable opportunity.
- 15.2 [DP], [NP] A boat not intending to race shall inform the race office before the scheduled warning

signal.

- 15.3 [DP] Any use of the engine for propulsion purposes for rescuing people, giving help or any other reason shall be reported after arrival in written form to the race committee stating the reasons for such procedure. If a boat does not gain a significant advantage in the race, the international jury may impose a discretionary penalty.

16 Replacement of crew or equipment

- 16.1 [DP] The technical committee may approve crew changes (adding new crew members, replacing or disembarking crew members) by written skipper's request made no later than 2 hours before the scheduled time of the start of the first race of the day. The substituted crew member shall not be aboard on any other competing boat throughout the remainder of the series. The weight of all crew members on board weighed in light street clothes after all crew changes shall not be greater than the maximum and smaller than the minimum as defined in ORC Rule 200.1. Crew substitutions in Corinthian Division shall also be valid World Sailing Category 1 sailors. If not, the entry will be scored in the Open Division.
- 16.2 [DP] Substitution of damaged or lost equipment is not allowed unless authorized in writing by the technical committee. Requests for substitution shall be made to the committee at the first reasonable opportunity, which may be after the race.

17 Equipment and measurement checks

- 17.1 A boat or equipment may be inspected at any time for compliance with the class rules, notice of race and sailing instructions.
- 17.2 [DP] When instructed by a race official on the water, a boat shall proceed to a designated area for inspection.

18 Official vessels

- 18.1 Vessels used by press, photographers, film crews, VIPs etc. are not under the jurisdiction of the race committee. Any action by these boats shall not be ground for request for redress by a boat. This changes RRS 62.1(a).

19 Support person vessels

[DP] Support person vessels shall keep well clear of the starting area and, after the preparatory signal, are not to approach within 100 meters of any competing boat. A breach of this SI may result with a scoring penalty against the boat connected and/or withdrawal of permission to be in the racing area for one or more days.

20 Radio Communication

- 20.1 [DP] Except in an emergency, a boat shall not make voice or data transmissions and shall not receive voice or data communication that is not available to all boats. This shall apply from the time she leaves her mooring for the first race of the day until racing for the day is complete.

APPENDIX 1 - BOW NUMBERS

[DP], [NP] Bow numbers shall be placed as forward as possible

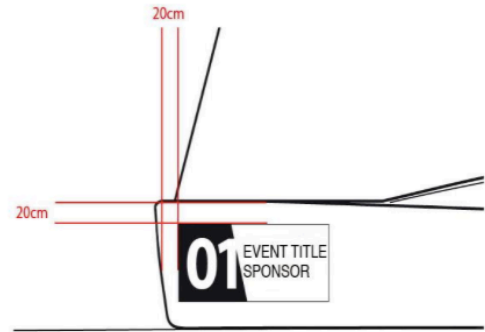
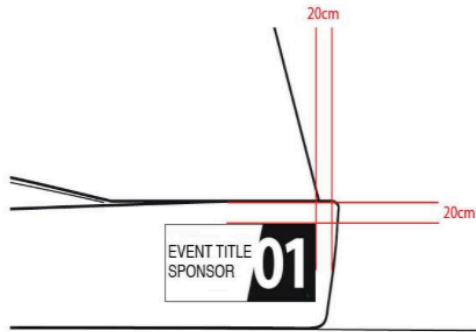

CORRECT



NOT CORRECT



APPENDIX 2 – W/L Races

The course is: Start – M1 (p) – M1a (p) – M2s/M2p – M1 (p) – M1a (p) - Finish

