



S.C.I.R.A.



"SERGIO MICHEL TROPHY"

South European Championship "Sergio Michel" Trophy  
III National Regata Snipe Class – Coppa Duca di Genova  
**Monfalcone, September 16th – 18th, 2022**

**Organizing Authority: Società Vela Oscar Cosulich – via dell’Agraria 50 34074  
Monfalcone tel 0481711325 e-mail [sport@avoc.org](mailto:sport@avoc.org), in cooperation with “Snipe  
Class International Racing Association” (SCIRA) – ITALIA**

## SAILING ISTRUZIONI

### 1. RULES

1.1 The regatta will be governed by the rules as defined in the Race Regulations (RRS).

2.2 Appendix P of the RRS will be applied, with the following changes:

- P2.1 First penalty  
When a boat is penalized a first time under rule P1.2 her penalty will be a One Turn Penalty under rule 44.2. If he fails to take the penalty, he will be disqualified without a hearing.
- P2.2 Second penalty  
When a boat is penalized the second time during the event, her penalty will be a Two Turns Penalty as per rule 44.2. If he fails to take the penalty, he will be disqualified without a hearing.
- P2.3 Third and subsequent penalties
- When a boat is penalized the third or subsequent times during the event, she shall promptly retire from the race. If he does not do so, he will be disqualified without a hearing and the score of that test cannot be discarded.
- P2.4 Penalty near the finish line
- If a boat is penalized in accordance with rule P2.3 and it was not reasonably possible for her to retire before finishing, she shall be classified as having promptly retired.

### 2. NOTICES TO COMPETITORS

Notices to competitors will be posted on the official notice board available on website [racingrulesofsailin.org](http://racingrulesofsailin.org), on the official website [www.svoc.org](http://www.svoc.org) and on telegram channel (<https://t.me/sudeuropeo>).



S.C.I.R.A.

### **3. CHANGES TO SAILING INSTRUCTIONS**

Any change to the sailing instructions will be posted 120 minutes before the first warning signal of the first race of the day it will take effect, except that any change to the schedule of races will be posted until 20h00 or until the protest time limit, whichever is later, on the day before it will take effect. 3.2 Any change or amendment to the Sailing Instructions shall be approved with the SCIRA Representative.

### **4. SIGNALS MADE ASHORE**

4.1 Signals made ashore will be displayed at the Mast Pole in front of the Race Office.

4.2 When the "AP" race signal is displayed ashore, '1 minute' is replaced with 'not less than 60 minutes' in the race signal "AP". 4.3 [NP] [DP].

4.3 [NP] [DP]. When the "AP over H" race signal is displayed ashore, the boats shall not leave the harbour. The warning signal will be exposed no less than 60 minutes after the signal is lowered with one sound.

### **5. REPLACEMENT OF CREW**

5.1 The same skipper shall sail all races and can be replaced after the first race only, and then only if he/she is obviously incapacitated. If a skipper is replaced the first race shall be the race dropped, or scored DNC.

5.2 The same crew shall race in all races, except for reasons satisfactory to the Race Committee. Requests for a change of crew shall be submitted in writing to the Chairman. Once a crew has been excused, he/she may not return for the balance of the series.

### **6. SCHEDULE OF RACES**

As per point 5 of the Notice of Race

### **7. CLASS FLAG**

The official Class Flag shall be the Snipe Class flag, a red Snipe on a white background.

### **8. RACING AREA**

Attachment "A" shows the location of the Racing Areas.

### **9. WEATHER LIMITATION**

9.1 The wind speed ranges shall be in accordance with the Rules of Conduct for Conducting National and International Championships

### **10. THE COURSES**

10.1 The diagrams below show the courses, including the approximate angles between legs, the order in which marks are to be passed. All course marks shall be left:



S.C.I.R.A.

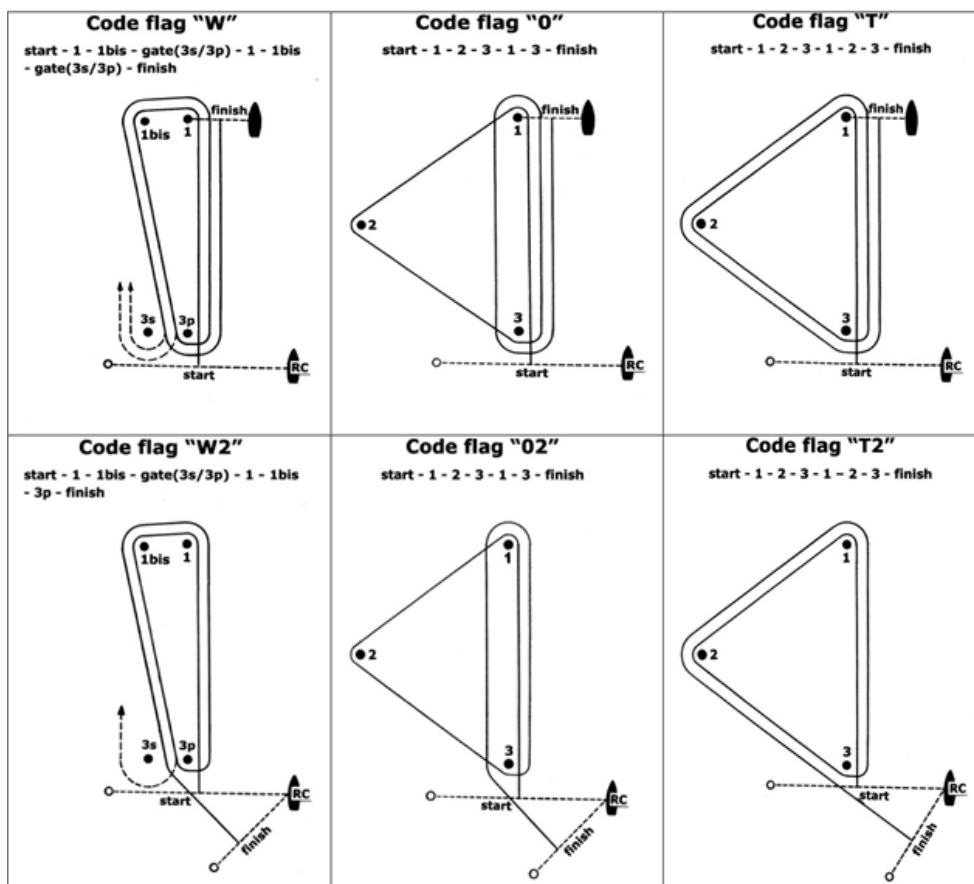

- 10.2 The course signal Flags (flag from ICS "W", "T", "O", "W2", "T2" or "O2") shall be hoisted with no sound signal no later than the warning signal. It will remain displayed for not less than five minutes after the start.
- 10.3 Mark 3 and gate 3s-3p will not constitute course mark on the first windward leg.
- 10.4 For courses "W" and "W2" in the event of the absence of a 3s-3p gate mark, the only remaining mark 3 must be left on the left.
- 10.5 If during a test on the course "W" and "W2" or on the "Olympic" course ("O", "O2") the wind increases to make the chosen course inappropriate, the race committee will change the type of course in, respectively, "Olympic" ("O", "O2") or "triangle" ("T", "T2"), displaying, at the buoy from which the change begins, the flag of the new course accompanied by repeated sound signals. Likewise, if the wind decreases during the race, the race committee will change the type of course by adopting one more suited to the new wind intensity, displaying the flag of the new course at the buoy from which the change begins.
- 10.6 A sustained wind variation of 20 degrees or more from the posted bearing during the first leg of a race shall result in the race to be abandoned and re-sailed, or abandoned. This changes the RRS 32.1.
- 10.7 A sustained wind variation of 40 degrees or more from the posted bearing during the first lap shall result in the race being abandoned and re-sailed, or abandoned. For the purpose of this rule a lap means the rounding of mark 3 (or passing the gate 3s-3p) for the first time. This changes the RRS 32.1.
- 10.8 The number of legs in a race may be reduced (RRS code flag S) but at least 2 (two) windward legs of the race shall be completed. This changes the RRS 32.2.



S.C.I.R.A.

## 11. MARKS

11.1 The port-end starting mark will be YELLOW

11.2 Marks 1, 1bis, 2, 3, 3s and 3p will be Conical ORANGE

11.3 The finishing mark for courses "W2", "O2", e "T2" will be a floating mark with a ORANGE flag displayed.

11.4 The new mark used for the change of the next leg of the course will be YELLOW.

## 12. CHECK IN

Before the warning signal of the first race of each day the boats must present themselves on the tack starboard, near and aft of the race committee boat for the start and verbally declare your sail number. A boat that does not comply with this instruction will receive, without a hearing, a penalty on the score of her first race of the day equal to the whole number (rounded to the nearest 0.5) closer to 10% of the number of boats entered (This changes rules. 44.3, 63.1 A4 and A5 of the RRS).

## 13. THE START

13.1 The races will be started as per rule 26 with a warning signal given 5 minutes before the starting signal.

13.2 The starting line will be between a staff displaying an orange flag on the Race Committee vessel at the starboard end and starting mark or a staff displaying an orange flag on a Race Committee vessel at the port end.

13.3 Una barca che parta più di 5 minuti dopo il segnale di partenza sarà classificata DNS – Non Partita, senza udienza (Ciò modifica regole A4 e A5).

13.4 A boat starting later than 5 minutes after her starting signal will be scored Did Not Start without a hearing. This changes Appendices A4 and A5.

13.5 The Race Committee, after the finish of a race and before the warning signal of a subsequent one, will do its best to post on the Race Committee vessel a list of OCS, UFD or BFD boats. The failure of posting or an incomplete or wrong list will not be grounds for redress. This changes the RRS 62.1(a).

## 14. CHANGE OF THE NEXT LEG OF THE COURSE

14.1 The change of course will be communicated to the competitors as per rule 33 of the RRS.

14.2 To change the next leg of the course, the Race Committee will lay a new mark (or move the gate or the finishing line) and remove the original mark as soon as practicable. When in a subsequent change a new mark is replaced, it will be replaced by an original mark.

14.3 If Mark 1 will be changed in courses "W" or "W2", Mark 1bis (offset) will no longer be a course mark.

14.4 Except at gate 3s-3p of the "stick" course, boats must pass between the race committee boat signaling the course change and the nearby buoy, leaving the buoy on the left and the race committee boat on starboard. (This change RRS28)

14.5 3 After the completion of first windward leg of the race the remaining legs may be increased or decreased by not more than 30% of the original length. This changes the RRS 33.

## 15. THE FINISH

15.1 The finishing line for courses "W", "O" and "T" will be between a BLUE flag pole placed on a race committee boat and mark 1.



## S.C.I.R.A.

15.2 The finish line of the courses "W2", "O2", "T2" will be between a pole with a BLUE flag placed on a boat of the race committee and the buoy defined in point 11.3 of the IdR.

## 16. PENALTY SYSTEM

16.1 Rule 44.1 is changed so that the Two Turns penalty is replaced by a One Turn penalty.

16.2 A boat that penalizes herself under rule 44.1 must submit the relevant declaration on [racingrulesofsailing.org](http://racingrulesofsailing.org) within the protest time limit (This changes rule 44.2).

## 17. SAFETY REGULATIONS

17.1 Before the warning signal of the first race of the day each boat is required to sail past the stern of the Committee boat signal boat on starboard tack and verbally check in

17.2 A boat that retires after finishing must notify the race committee of its decision in writing, within the time limit for protests.

## 18. TIME LIMITS

18.1 The races will be managed to last 60-75 minutes for the first boat to finish. A different time (shorter or longer) used to complete the race will not be ground for requesting redress.

18.2 The time limit for the first boat to finish the race shall be 90min

18.3 Any boat finishing more than 30 minutes after the first boat finishes or failing to finish within 2 hours from the start, whichever is shorter shall be scored Did Not Finish (DNF). This changes RRS 35, A4 and A5.

18.4 The race committee may cancel the race if the first boat does not complete the first lap within 40 minutes of the start. For this instruction, "first lap" means the course taken from the beginning to passing for the first time to mark 3, or to port 3s-3p (modification of rule 35, A4 and A5).

## 19. PROTESTS AND REQUESTS FOR REDRESS

19.1 Protest forms are available on the Racing Rules of Sailing. Protests and requests for redress or reopening shall be delivered there or at the following link within the appropriate time limit.

19.2 The protest time limit is 90 minutes after the last boat has finished the last race of the day or the Race Committee signals no more racing today, whichever is later.

19.3 Notices will be posted no later than 30 minutes after the protest time limit to inform competitors of hearings in which they are parties or named as witnesses and the place where the hearings will be held.

19.4 On the last day of racing:

- a request for redress must be submitted no later than the time limit for protests or 30 minutes after the accident, whichever is the later (amendment to rule 62.2);

- a request for reopening of the hearing must be presented:

- a) within the protest time limit, if the requesting party was informed of the decision the previous day (rule 66 change);

- b) no later than 30 minutes, after the requesting party has been informed of the decision on that day (amendment to rule 66).

## 20. SCORING

As per point 11 of the Notice of Race.



S.C.I.R.A.

**21. EQUIPMENT AND MEASUREMENT CHECKS**

A boat or equipment may be inspected at any time for compliance with the Class Rules and Sailing Instructions. On the water, a boat can be instructed by a member the Technical Committee, or the equipment inspector or measurer, to proceed immediately to a designated area for inspection

**22. OFFICIAL BOATS**

Official Boats will be marked with a white flag with “S”.

**23. RADIO COMMUNICATIONS**

A boat that is racing shall not make voice or data transmissions and shall not receive voice or data communication that is not available to all boats, except in an emergency or when using equipment provided by the race committee

**24. DRONES**

No drones are allowed closer than 500 m from racing areas from the Warning Signal for a race and after the last boat has finished the race. As a penalty for breaching this rule the protest committee may impose a discretionary penalty (DP) to all boats associated with the owner / operator of the drone. This does not apply to OA drones.

**25. RISK STATEMENT**

RRS 3 states: “The responsibility for a boat’s decision to participate in a race or to continue racing is hers alone”. There for, the participants are aware date the sailing activity falls within does governed by Article 2050 of the Italian Civil Code and that alla participants must have a valid FIV membership that garantees accident coverage, included death and permanent disability.

**26. PRIZES**

As per Notice of Race.

**THE ORGANIZING COMITTEE**



S.C.I.R.A.



## BOW NUMBERS

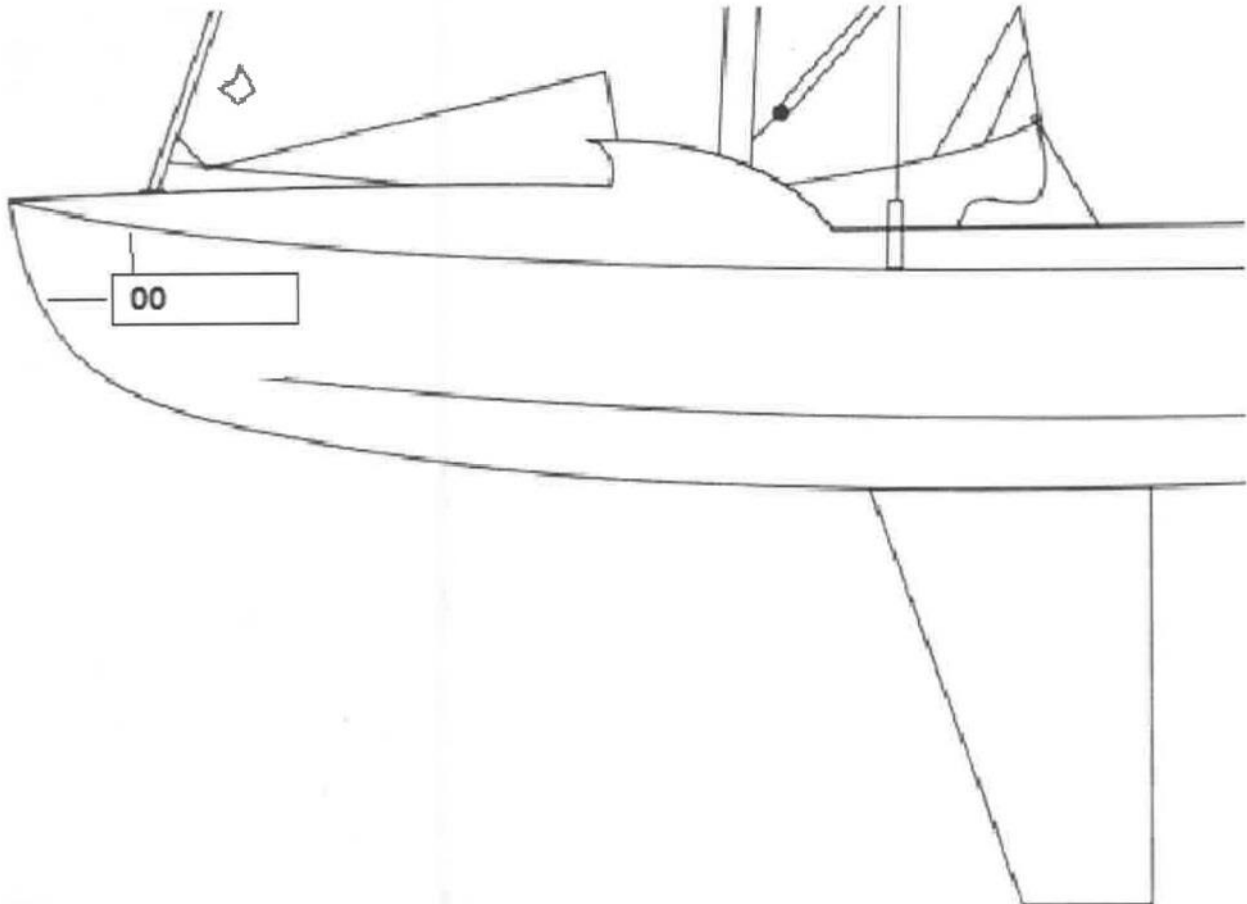

The bow number must be applied horizontally according to the following indications:

- Maximum 25cm distance between the bow and the edge of the adhesive
- 5 cm away from the top edge of the hull