



Jedriličarski klub  
**GALEB** Kostrena

# UPUTE ZA JEDRENJE OPEN CROATIA NATIONALS 2021

*Šljuka*

*01-03. 10. 2021.*

## **Organizacijski odbor**

Robert Scheidl  
Stasio Scarpa  
Milko Volarić

## **Regatni odbor**

Vilim Nakrst NS  
Miljenko Sokolić S  
Robert Scheidl S  
Bartol Hodanić S

## **Osiguranje na moru**

Lučka kapetanija Rijeka

## **Odbor za prosvjedu**

Dražen Zdelarec IRO  
Nena Mareljć Iussich NS  
Marion Sikić NS

## 1 RULES

- 1.1 The regatta will be governed by the rules as defined in The Racing Rules of Sailing 2021 - 2024 (RRS).
- 1.2 The SCIRA Rules of Conduct for Conducting National and International Championship Regattas (RoC) available at [https://www.snipe.org/images/2021/SCIRA\\_2021\\_Rules\\_of\\_Conduct\\_final.pdf](https://www.snipe.org/images/2021/SCIRA_2021_Rules_of_Conduct_final.pdf);
- 1.3 The RRS as modified by the Rules for Conducting National and International Championship Regattas (RoC) as specified in the Sailing Instructions;
- 1.4 No national prescriptions will apply;
- 1.5 In case of a conflict between the Notice of Race and Sailing Instructions, the latter shall apply;
- 1.6 If there is a conflict between languages the English text will take precedence;
- 1.7 It is advisable to check <http://www.healthmap.org/en> consult your travel agent, or the Consulate General of your country for the current health advisory regarding travel to Croatia. Due to the agreement between the organizing club and the Croatian Sailing Federation, the World Sailing "Coronavirus (COVID-19) Guidance for Event Organisers for the Protection of the Health for Sailing Communities" is in place for this event. For more information refer to <https://www.sailing.org/medical/index.php> G.3. It is strongly recommended that you bring your own protective face mask and any additional personal protection with you.

## 2 NOTICES TO COMPETITORS

Notices to competitors will be posted on the online official notice board available on this link: <https://www.racingrulesofsailing.org/documents/2739/event>

## 3 CHANGES TO SAILING INSTRUCTIONS

3.1 Any change to the sailing instructions will be posted before 10:00 on the day it will take effect, except that any change to the schedule of races will be posted by 20:00 on the day before it will take effect.

## 4 SIGNALS MADE ASHORE

- 4.1 Signals made ashore will be displayed at signal pool located in front of the sailing club boat hangar.
- 4.2 When the "AP" race signal is displayed ashore, '1 minute' is replaced with 'not less than 30 minutes' in the race signal "AP".
- 4.3 When the "AP over H" race signal is displayed ashore, the boats shall not leave the harbour. The warning signal will be exposed no less than 30 minutes after the signal is lowered with one sound.

## 5 SCHEDULE OF RACES

5.1 Dates of racing:

Date

Time of first

Warning Signal

October 01<sup>th</sup> 13:00 Racing

October 02<sup>nd</sup> 09:00 Racing

October 03<sup>rd</sup> 09:00 Racing

5.2 The regatta shall consist of 6 races.

5.3 No more than three (3) races shall be sailed per day.

5.4 In case of a prolonged postponement, to alert boats that a race or sequence of races will begin soon, an orange flag will be displayed with one sound for at least four minutes before a warning signal is made. Failures to observe this instruction are not grounds for redress.

5.5 On the last day of racing no warning signal will be made after 16:00.

5.8 There will be a competitors meeting on October 01<sup>th</sup> at 11:00 in front of the sailing club boat hangar.

## 6 CLASS FLAGS

The official Class Flag shall be the Snipe Class flag, a red Snipe on a white background.

## 7 RACING AREAS

The Racing Area location chart is posted on the Official Notice Board.

## 8 WEATHER LIMITATION (Course and Starting)

The wind speed ranges shall be in accordance with the Rules of Conduct for Conducting National and International Championships and the applicable Deed of Gift.

## 9 THE COURSES

9.1 The diagrams below show the courses, including the approximate angles between legs, the order in which marks are to be passed. All course marks (except gates) shall be left to port.

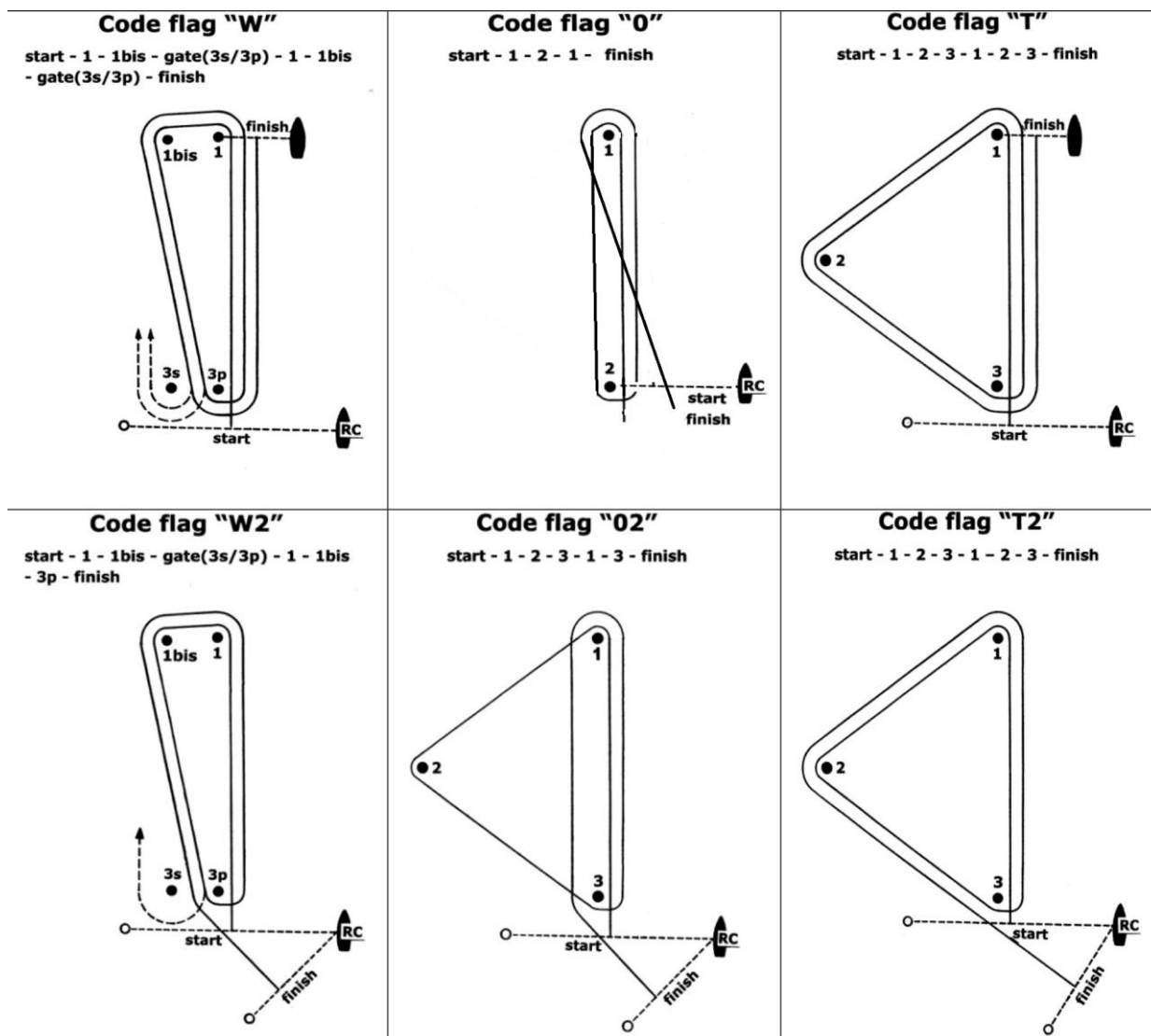

9.2 The course signal (code flag "W", "T", "O", "W2", "T2" or "O2") shall be hoisted with one sound at last one minute before the warning signal. It will remain displayed for not less than five minutes after the start.

9.3 No later than the warning signal, the Race Committee signal boat will display the approximate compass bearing of the first leg.

9.4 If during a race the wind and/or wave action changes to the point where the selected course would be inadvisable (See Course Selection Diagram), the Race Committee shall change the course at any mark. A change of the type of course during the race shall be signalled displaying the new appropriate flag and accompanied by repetitive sounds before the leading boat has passed or rounded the mark.

9.5 The number of legs in a race may be reduced (RRS code flag S) but at least 2 (two) windward legs of the race shall be completed. This changes the RRS 32.2.

9.6 A sustained wind variation of 20 degrees or more from the posted bearing during the first leg of a race shall result in the race to be abandoned and re-sailed, or abandoned. This changes the RRS 32.1.

9.7 A sustained wind variation of 40 degrees or more from the posted bearing during the first lap shall result in the race being abandoned and re-sailed, or abandoned. This changes the RRS 32.1.

#### 10 MARKS

10.1 Marks 1, 3, 3s and 3p will be cylindrical yellow buoys, Mark 2 will be cylindrical red buoy.

10.2 New marks, as provided in instruction 12.1, will be cylindrical yellow buoy.

10.3 The port-end starting mark will be a vessel with orange flag displayed.

10.4 The finishing mark will be inflatable cylindrical red buoy.

10.5 A Race Committee vessel signalling a change of a leg of the course is a mark as provided in SI 13.2.

10.6 If one of the marks "gate 3s-3p" is not placed, or is not replaced as per RRS 34, the remaining mark shall be left to port.

This changes the RRS 34.

#### 11 THE START

11.1 RRS 30.4 will be changed so that it will be applied in fleet with more than 45 boats and after the 2nd General Recall only

11.2 The starting line will be between a staffs displaying an orange flag on the Race Committee vessel at the starboard end and red cylindrical boy on port.

11.3 A boat starting later than 5 minutes after her starting signal will be scored Did Not Start without a hearing. This changes Appendices A4 and A5.

## 12 CHANGE OF THE NEXT LEG OF THE COURSE

12.1 To change the next leg of the course, the Race Committee will lay a new mark (or move the finishing line) and remove the original mark as soon as practicable. When in a subsequent change a new mark is replaced, it will be replaced by an original mark.

12.2 Except at a gate, boats shall pass between the race committee boat signalling the change of the next leg and the nearby mark, leaving the mark to port and the Race Committee vessel starboard. This changes the RRS 28.

12.3 After the completion of first windward leg of the race the remaining legs may be increased or decreased by not more than 30% of the original length. This changes the RRS 33).

12.4 If Mark 1 will be changed in course "W", Mark 1bis (offset) will no longer be a course mark.

## 13 THE FINISH

13.1 The finish line will be between a staff displaying an orange flag on a Race Committee vessel and the course side of the finishing mark as provided in 10.4.

13.2 The A flag on the Race Committee boat at the finish means that there will be no more races for the day.

## 14 TIME LIMITS AND TARGET TIMES

14.1 The races will be managed to last 60-75 minutes for the first boat to finish. A different time (shorter or longer) used to complete the race will not be ground for requesting redress.

14.2 The time limit for the first boat to complete the first lap is 40 minutes from the start. If the first boat fails to complete the first lap within 40 minutes the Race Committee shall abandon the race. For the purpose of this rule a lap means the rounding of Mark 3 or 1 (or passing the Gate 3s/3p) for the first time.

14.3 The time limit for the first boat to finish the race shall be 1 hour, 30 minutes. Any boat finishing more than 30 minutes after the first boat finishes or failing to finish within 2 hours from the start, whichever is shorter shall be scored Did Not Finish (DNF). This changes RRS 35, A4 and A5.

## 15 PROTESTS AND REQUESTS FOR REDRESS

15.1 Protest forms are available online at <https://www.racingrulesofsailing.org/documents/2739/event>.  
Protests and requests for redress or reopening shall be delivered there within the appropriate time limit.

15.2 The protest time limit is 90 minutes after the last boat has finished the last race of the day or the Race Committee signals no more racing today, whichever is later.

15.3 Notices will be posted no later than 30 minutes after the protest time limit to inform competitors of hearings in which they are parties or named as witnesses. Hearings will be held in the protest room, located on the first floor of the Sailing club administrative building, beginning at the time posted.

15.4 Notices of protests by the Race Committee or Protest Committee will be posted to inform boats under RRS 61.1(b).

15.5 A list of boats that have been penalized for breaking RRS 29.1 (OCS) or 30.1 (OCS) or 30.2 (ZPF) or 30.3(UFD) and 30.4 (BFD) will be posted on the Official Notice Board (<https://www.racingrulesofsailing.org/documents/2739/event>).

15.6 On the last scheduled day of racing a request for redress based on a protest committee decision shall be delivered no later than 30 minutes after the decision was posted. This changes the RRS 62.2.

15.7 The Jury will abandon the race if, during a redress hearing, they conclude that the Race Committee did not follow Sailing Instructions 8, 9.5, 9.6, and 9.7. This changes the RRS 64.2.

## 16 SCORING

16.1 3 races are required to be completed to constitute a series. [\*per SCIRA Rules, Deed of Gift, etc.\*]

16.2 (a) When fewer than 4 races have been completed, a boat's series score will be the total of her race scores.

(b) When 4 or more races have been completed, a boat's series score will be the total of her race scores excluding her worst score.

## 17 SAFETY REGULATIONS

17.1 Before the warning signal of the first race of the day each boat is required to sail past the stern of the Race Committee boat on starboard tack and verbally check in. When the Race Committee verbally acknowledges a boat's sail number, the checkin has been officially noted.

17.2 A boat that retires from a race (DNF) shall notify the Race Committee as soon as possible.

## 18 REPLACEMENT OF CREW OR EQUIPMENT

18.1 The same crew shall race in all races, except for reasons satisfactory to the Race Committee. Requests for a change of crew shall be submitted online at <https://www.racingrulesofsailing.org/documents/2739/event>. Once a crew has been excused, he/she may not return for the balance of the series.

18.2 The same skipper shall sail all races and can be replaced after the first race only, and then only if he/she is obviously incapacitated. If a skipper is replaced the first race shall be the race dropped, or scored DNC.

#### 19 EQUIPMENT AND MEASUREMENT CHECKS

A boat or equipment may be inspected at any time for compliance with the Class Rules and Sailing Instructions. On the water, a boat can be instructed by a member of the Race Committee, or the Technical Committee, or the equipment inspector or measurer, to proceed immediately to a designated area for inspection.

#### 20 SUPPORT BOATS

20.1 At the preparatory signal, support boats must be positioned at least 50 meters below the starting line. After the starting signal support boats may follow the fleet, but only on the port side of the course and must stay 50 meters from any mark

20.2 Support personnel may not communicate with competitors after the warning signal for any race until after the competitors have finished of the race.

#### 21 RADIO COMMUNICATIONS

A boat shall neither make or receive radio transmissions while racing nor receive radio communications not available to all boats, except in an emergency or when using equipment provided by the race committee. This restriction also applies to mobile telephones.

#### 22 TRASH DISPOSAL

Trash may be placed aboard support and Committee Vessels.

#### 23 PRIZES

Prizes shall be awarded as provided by NoR.